

C 4 G I A N T

F L E X I B I L I T Y I N P R O D U C T I O N

The Kalmar MailPro C4 Giant mail-inserting machine is extremely flexible and can be customized to the specific needs of your business! The C4 Giant handles both administrative mail (billing, personalized letters etc) and direct mail (adverts, books, giveaways, CDs etc) with the greatest degree of accuracy and security.



NEW FEATURES

- Servo drive for multi-feed from stations and improved high-speed endurance
- Improved HMI-system
- Diagnostic function
- Improved water system
- High capacity envelope station
- New design

The C4 Giant is a modular system, which enables a single system to process multiple applications. It can be customized to handle a specific task or easily set up for different kinds of jobs depending on customer requirements. It is available in versions ranging from handling 2 inserts to a 16-station tandem machine. The C4 Giant handles different quantities of enclosures depending on customer requirements – enabled by optical reading (BCR, OMR, ICR etc). It handles envelopes from size C6 to C4/B4.

A wide range of accessories, stand-alone and channel-modules (see separate product-sheet) are available to make this one of the most versatile inserters on the market!

C4 GIANT

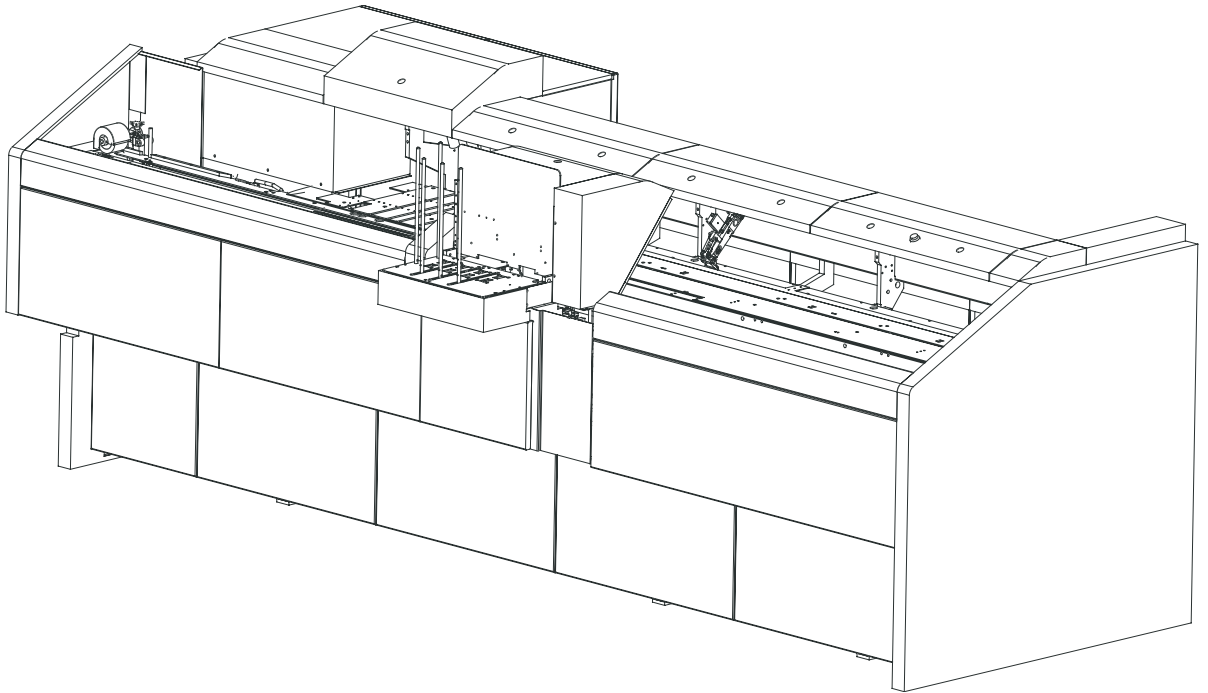

SPECIFICATION C4 GIANT

ENVELOPES:

Max. size: 270 x 360 mm
Min. size: 90 x 162 mm
Flap depth: 25 - 76 mm

INSERTS:

Max. size: 235 x 330 mm
Min. size: 80 x 150 mm
Max. thickness: 9 mm (in total up to 16 mm)
25 mm as option
Min. thickness: 40 g/m² single sheet
Stations: 2 - 12 standard
Speed: up to 7 000 cycles/hour

Power requirement: 400/230VAC, 3 phase, 50 Hz, 16 A

Space requirement: 4 stations 2.6 x 1.2 m
6 stations 3.3 x 1.2 m



New, easily accessible water system.



Improved Human-Machine Interface system.

 **KalmarMailPro**

PO Box 991, SE-391 29 Kalmar, Tel: +46 480 546 50, Fax: +46 480 546 55
e-mail: order@kalmarmailpro.se
www.kalmarmailpro.se